

Litton

**ENGINEERING
LABORATORIES**

Quality, Precision Alignment

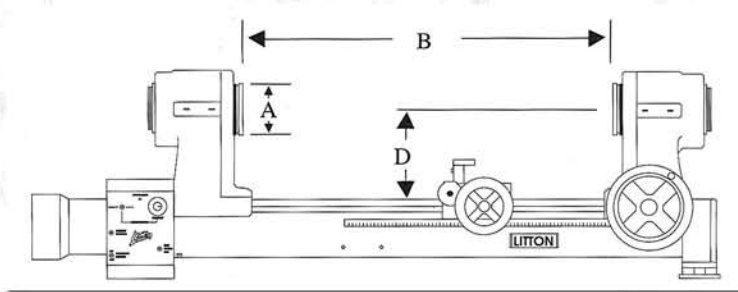

**Bench lathes
Chucks
Burners
Refurbishing**

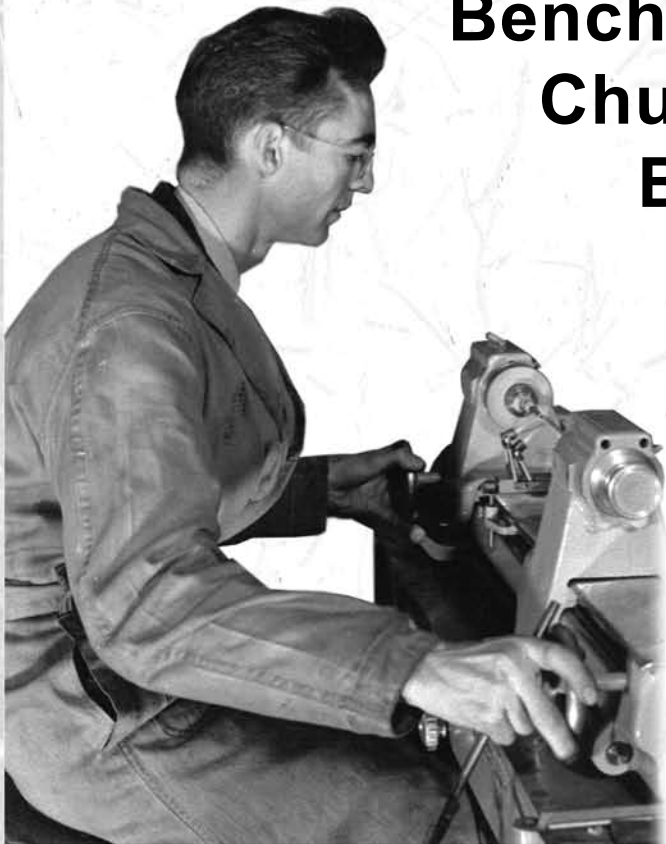

photo: Charles Litton Sr.

800-821-8866 / 530-273-6176 / www.Littonengr.com

Litton Engineering Labs, 200 Litton Dr., Suite 200, Grass Valley, CA 95945

Litton

ENGINEERING
LABORATORIES

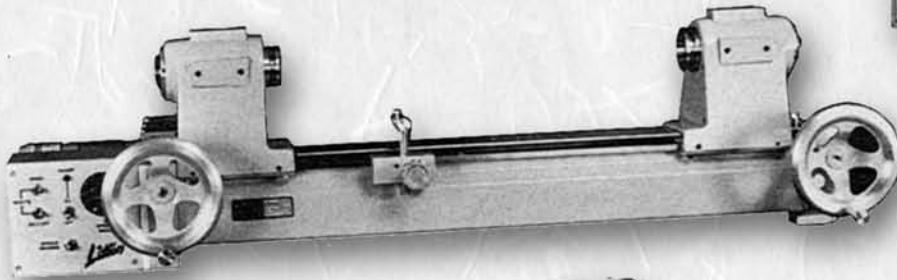

model F053



model U077

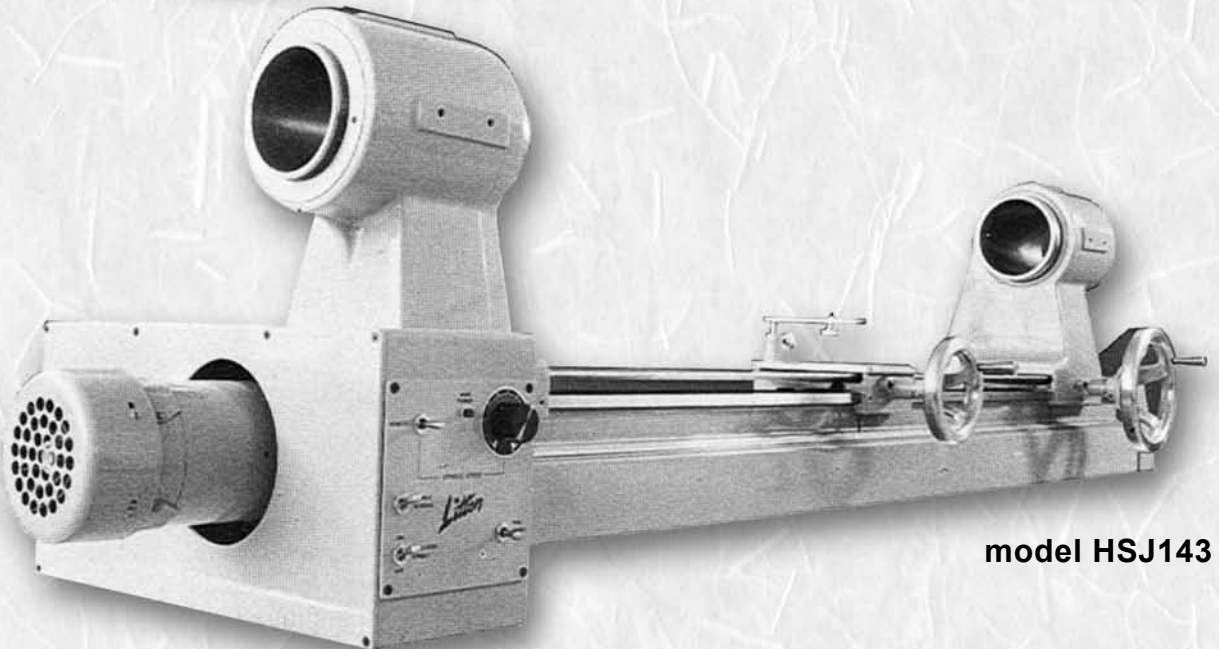

model HSJ143

Bench Model Lathes

800-821-8866 / 530-273-6176 / www.Littonengr.com

Litton Engineering Labs, 200 Litton Dr., Suite 200, Grass Valley, CA 95945

Bench Model Lathes

Fine quality Litton bench model lathes feature precision alignment. All Litton Bench Model Lathes have an infinitely variable belt drive (timing belt for F053 and "V" belt for all others) with the following features: spindle ON/OFF, speed and direction controls, and sockets which allow connection of remote control devices for control of spindle ON/OFF and speed functions. Bench models excepting the F053 lathe also have a switch for tail stock spindle ON/OFF and a jog switch for the spindles.

Lathes can be purchased with motorized fire carriage and a tail stock. Models F053 and U077 come standard with a rack and pinion fire carriage burner bracket which allows effortless vertical adjustment of the burner assembly. Lathe bed scales are a standard feature on all lathes.

Lathe spindles contain seals which make it possible to apply air pressure to the work through the spindles. Litton also offers an optional Swivel/Stop System which delivers both pressure and vacuum directly to the work. This system will accommodate different sized stops which are easily changed to accommodate varied glass sizes

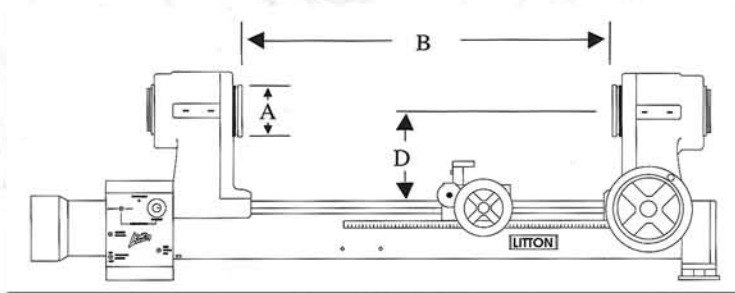

A = Spindle Bore Diameter
 B = Maximum Length,
 Spindle Nose to Spindle Nose
 D = Radial Clearance Above
 Heat Shield

Bench Lathe Model#	A	B	D	Spindle Speed RPM
F053	33 mm 1-5/16"	527 mm 20-3/4"	102 mm 4"	20 - 400
U077	79 mm 3-1/8"	772 mm 30-3/8"	149 mm 5-7/8"	10 - 300
HSA093	67 mm 2-5/8"	927 mm 36-1/2"	232 mm 9-1/8"	10 - 300
HSJ093	114 mm 4-1/2"	927 mm 36-1/2"	232 mm 9-1/8"	10 - 240
HSJ143	114 mm 4-1/2"	1429 mm 56-1/4"	232 mm 9-1/8"	10 - 240
HTJ093	114 mm 4-1/2"	927 mm 36-1/2"	350 mm 13-3/4"	10 - 240
HTJ143	114 mm 4-1/2"	1429 mm 56-1/4"	350 mm 13-3/4"	10 - 240

Electrical Supply Required: 110 - 120V AC, 50 - 60 Single Phase

Options

Burner Mounts & Firecarriage Covers

Pictured to the left is a standard firecarriage and burner mount. Pictured to the right is a firecarriage with an optional T-slot firecarriage cover and rack and pinion burner mount: the latter allows vertical adjustment of the burner by merely turning a conveniently located knob. Also included in the assembly is an auxiliary mounting bar for mounting additional accessories. The rack and pinion burner mount is standard on the F053 and U077 Lathes only. Both burner mount and firecarriage cover are to be specified when lathes are purchased.

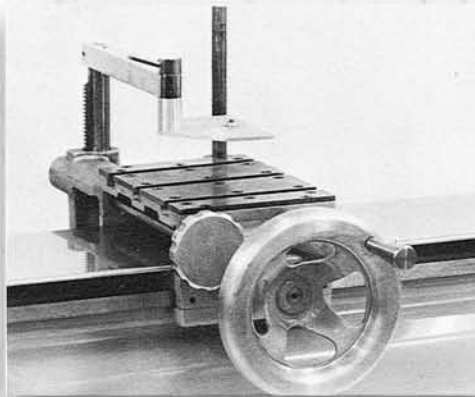
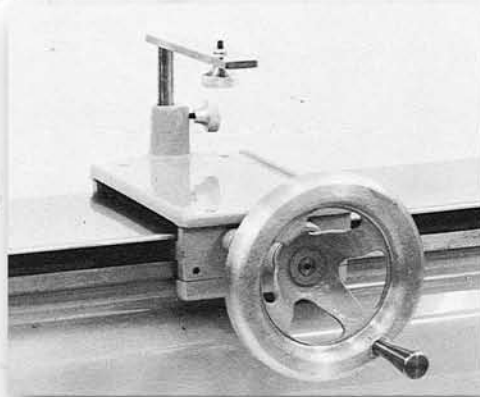

Benches

Two types of benches are available; plumbed and basic. Plumbed benches have a stainless steel top and a black backboard. They are plumbed with three manifolds; one for gas, air or oxygen would be connected to the lathe (see valve handles on left of bench). These same manifolds also supply gas and oxygen for a hand torch, and gas and air for an annealing burner. Again, there are cut off needle valves (see valve handles on right of bench). Basic benches are not plumbed and do not have a backboard.

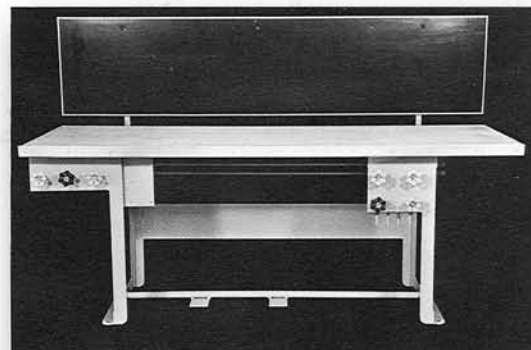

Valves

Litton offers three types of valves, two of which control both the volume and proportion of gas and oxygen to burners: a rotary cock gas-oxy proportioner, volume control and spindle air control valve; a piston type gas-oxy proportioner, volume control valve; and a rotary cock spindle air and vacuum control valve.

Chucks

To complete the versatility of Litton Lathes, a variety of chucks are available. Outboard spindle nose adaptors (OBSNA) mount to the outboard side of the spindle. They permit chucks to be mounted to the rear of the spindle. Guiding Chucks mount to the outboard side of the spindle to guide pieces of tubing that extend through the spindle. Bench model lathes are listed below with types of chucks which can be purchased for them.

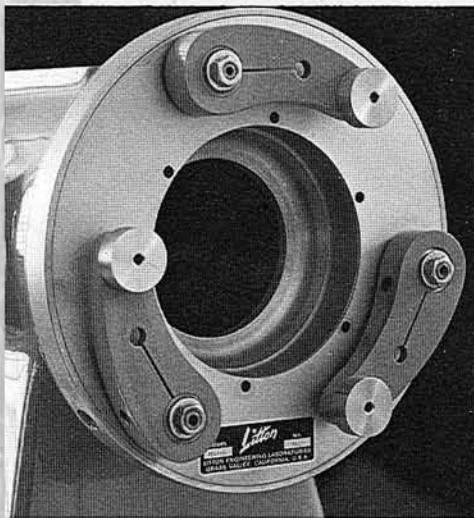

F053

Speed
Drill
Scroll
3-Jaw

—
—
—

U077

Speed
Drill
Scroll
3-Jaw

—
—
—

H Series

Speed
Drill
Scroll
3-Jaw
6-Jaw
4-Jaw
Guiding

Burners

Litton cradle burners are offered in standard and swivel configurations. Ring configuration are also available but are not pictured. All burners are surface mix and can be purchased constructed of chromium plated brass or stainless steel. Annealing and hand torches are also available.

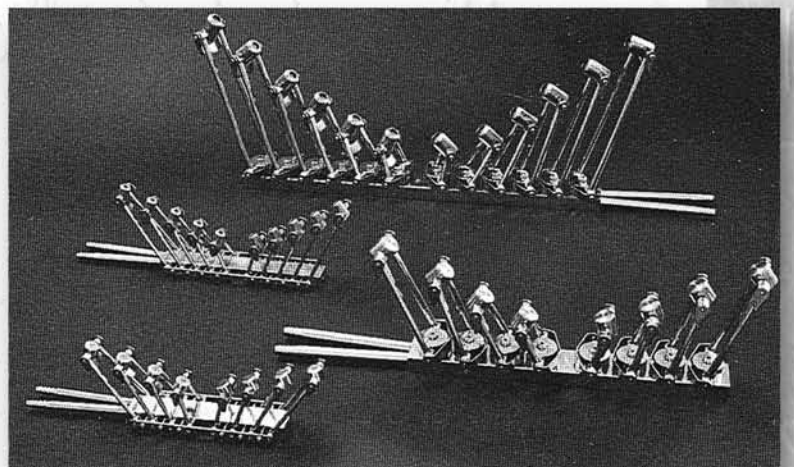

800-821-8866 / 530-273-6176 / www.Littonengr.com

Litton Engineering Labs, 200 Litton Dr., Suite 200, Grass Valley, CA 95945

**Standard "F"
Plus 5C Collet
Spindles & Mechanism**



**Standard "F"
Firecarriage with Rack & Pinion
Burner Mount**



**Standard "F"
Plus 5C Collet Spindles & Mechanism
Plus FC Chuck
Plus 4" Bison Chuck**

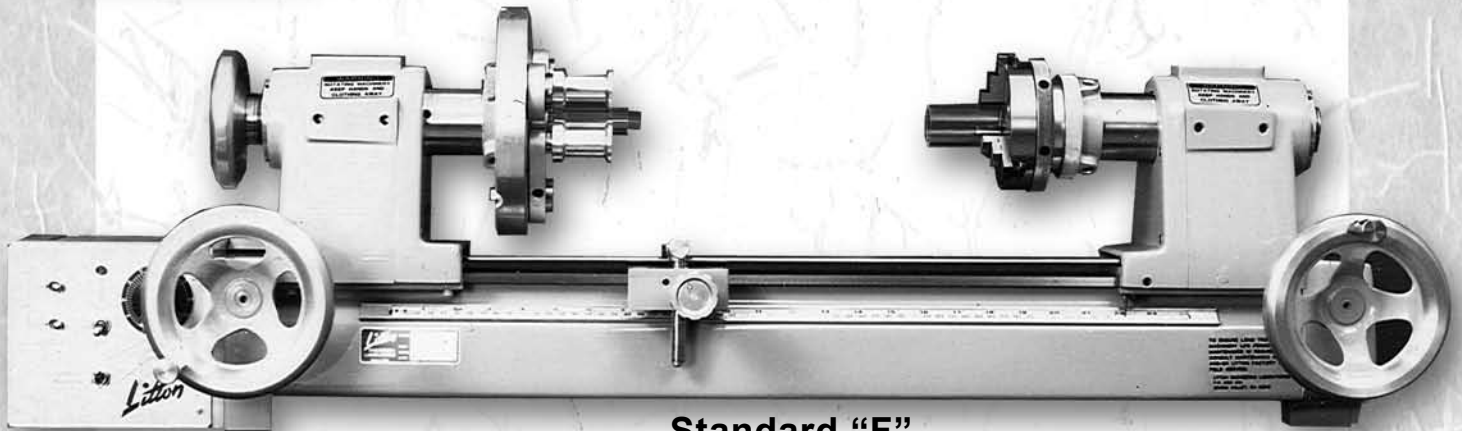

LATHES

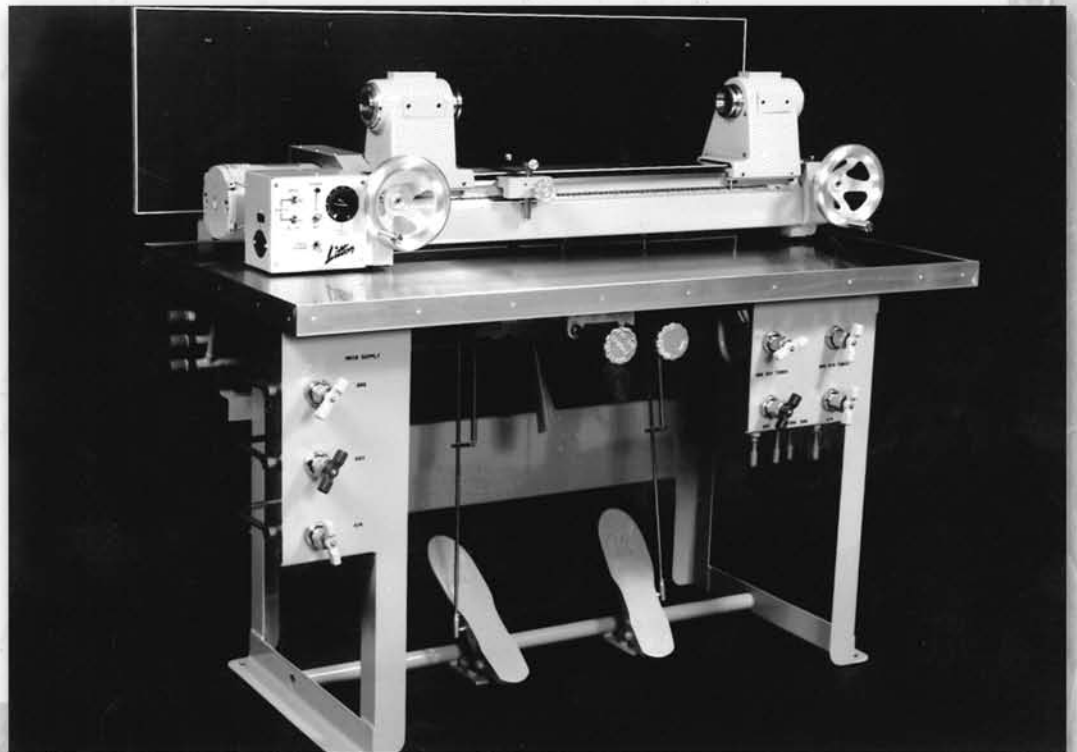
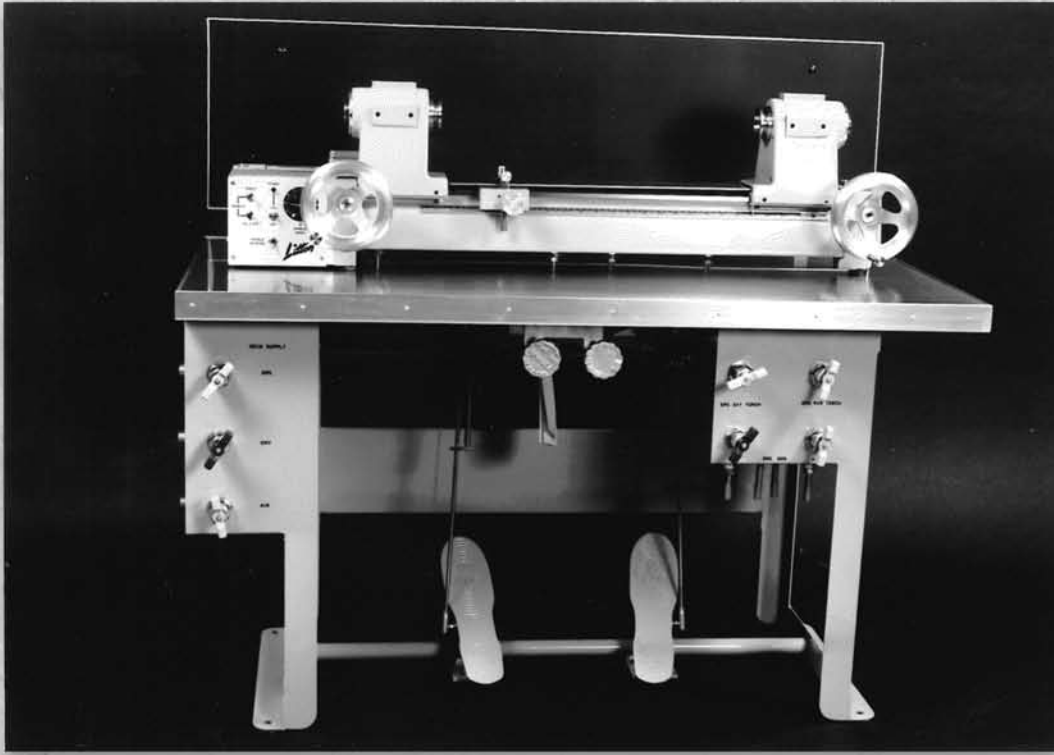

Litton
ENGINEERING
LABORATORIES

**HS T-Slot Fire Carriage
Rack & Pinion Burner Mount**

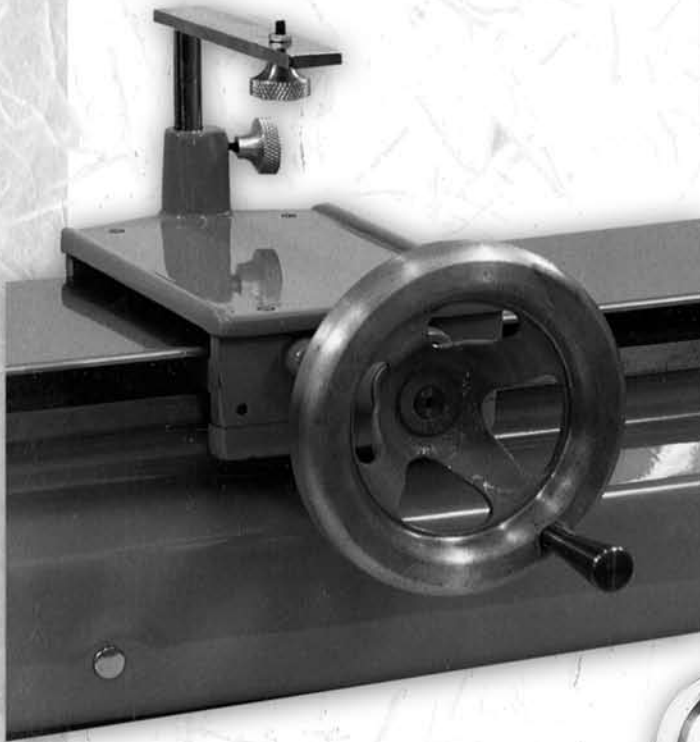
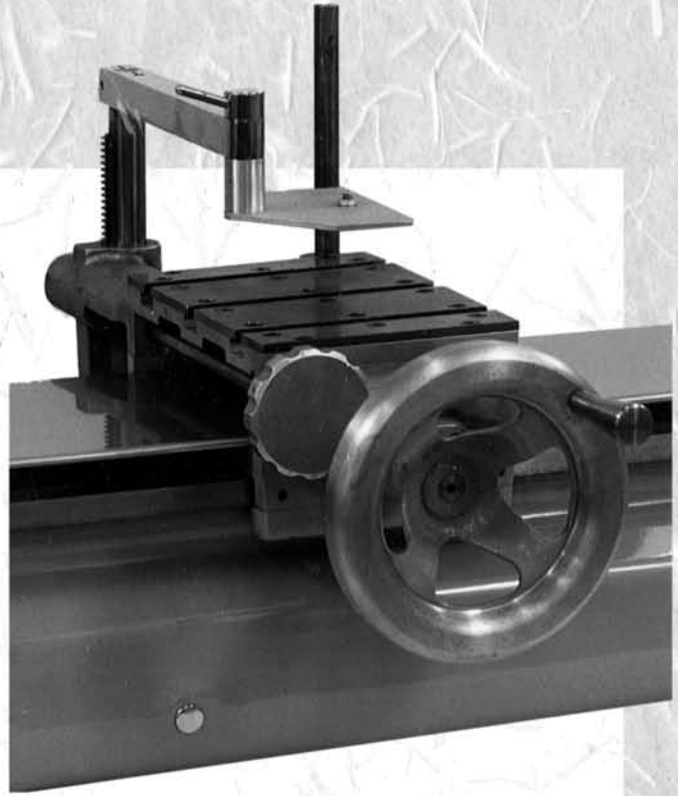

**HS Firecarriage
Standard FC Cover
Standard Burner Mount**

“F” with 5C Spindle





EE171 Automated

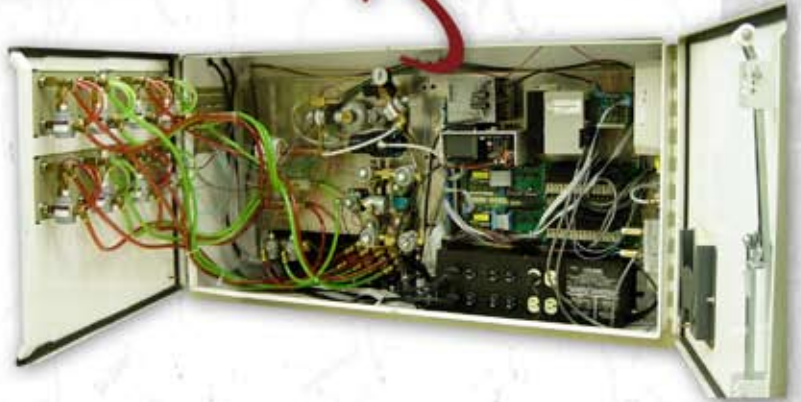

LATHES

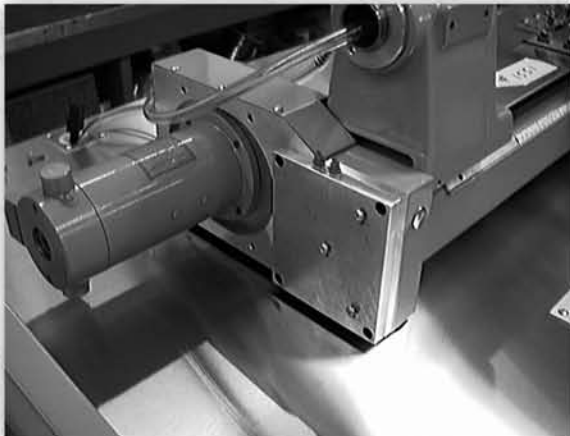
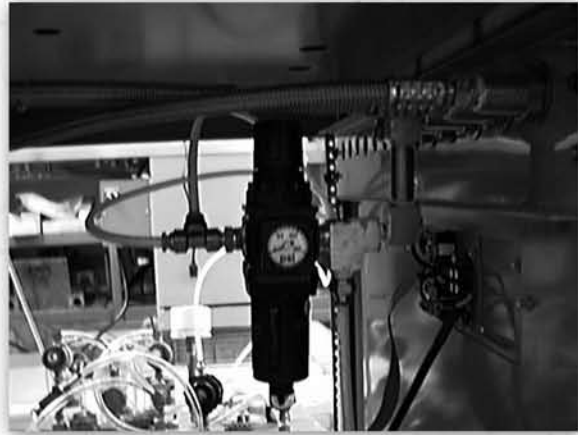
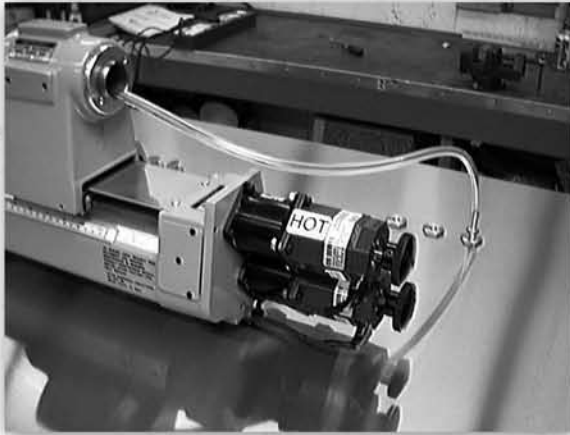
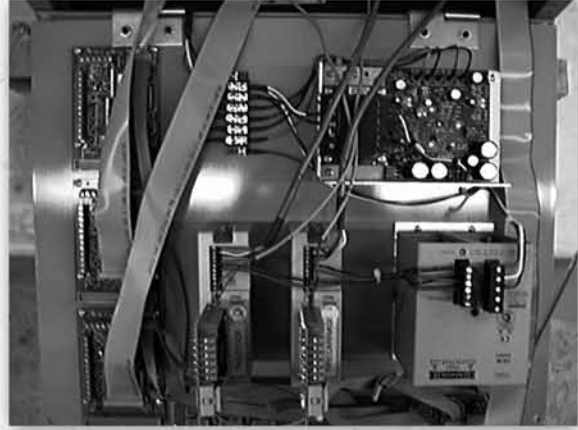



**HSJ Standard
No Fire Carriage**

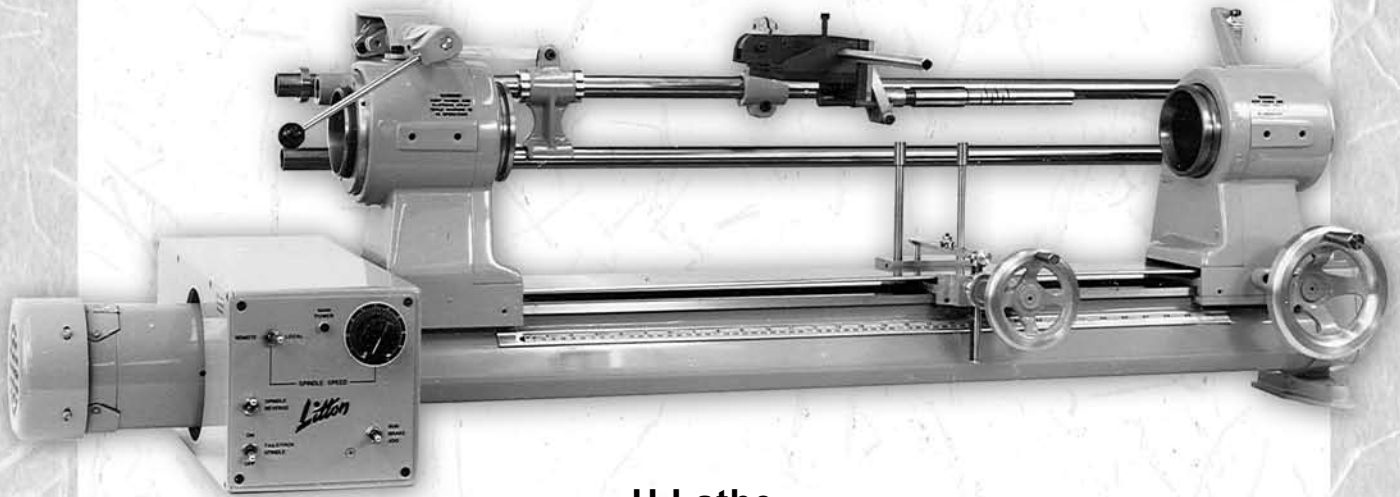

**U Lathe
with Drag Bar & Rack & Pinon Burner Mount**

LATHES

**HTJ
Headstock**

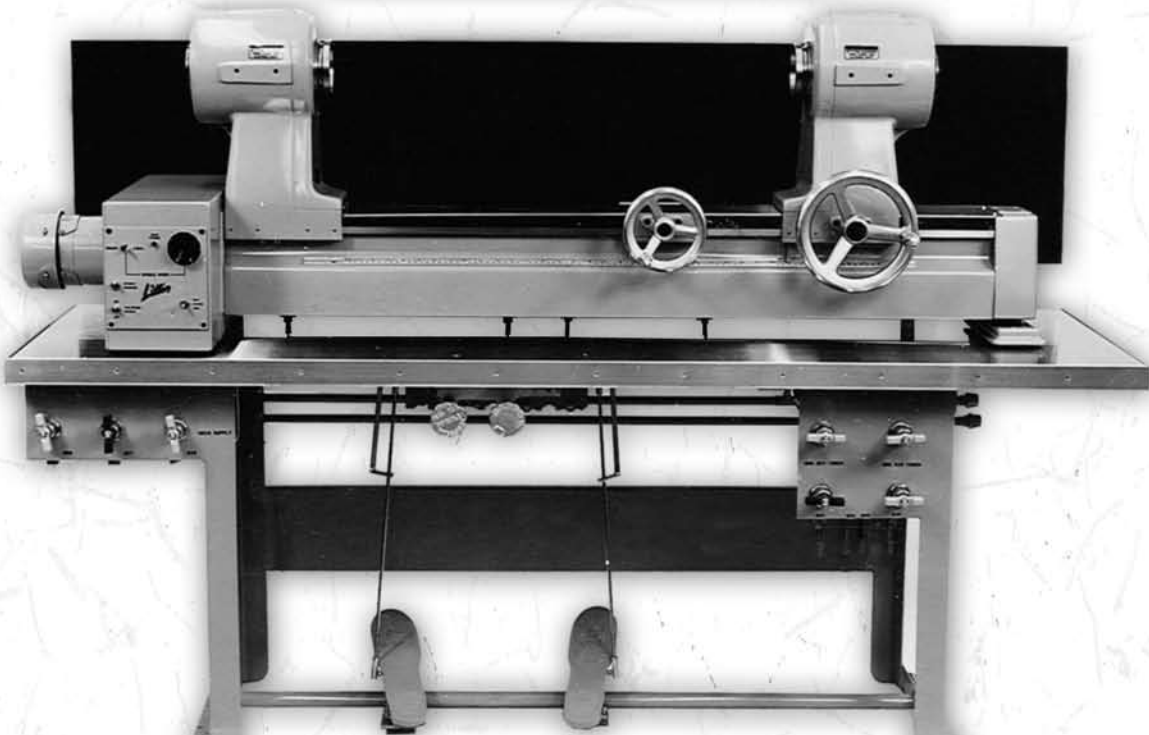

Fully plumbed bench with rotary cock valve

Litton

**ENGINEERING
LABORATORIES**